

SmartBank Standard owners/installation manual

We have been forced to add the following warnings to this manual.

WARNING. Incorrect installation of this product may result in serious damage to the unit which will **NOT** be covered under warranty.

Pay particular attention to the following:-

Incorrect battery polarity should not affect the unit. It simply will not work. However, if used in conjunction with the SmartGauge, incorrect battery polarity will almost certainly damage one or both units. Such installation leaves very distinct tell tale signs in both units and will **NOT** be covered under warranty.

Use of the incorrect type of communications cable between SmartGauge and SmartBank may damage one or both units. Such damage will **NOT** be covered under warranty.

No matter how careful you think you are **NEVER** attempt to carry out any work, whether installation or modification, to any live electrical circuits. Disconnect **ALL** forms of power before doing any installation or modification work. Failure to adhere to this simple rule will almost certainly result in damage to the equipment which will **NOT** be covered under warranty. It only takes one simple slip with a screwdriver or wire for just one nanosecond to do several hundred pounds-worth of damage.

The C1 and C2 terminals carry **POWER** signals to the relay coil. Short circuiting these together and/or to the battery positive or battery negative will almost certainly damage the unit. Quite possibly beyond repair. Such damage will **NOT** be covered under warranty.

If using an SW180-2 relay pay particular attention to the relay coil terminals. There are not 4 terminals. There are 2. The opposite posts of each terminal are the same conductor. Connecting C1 and C2 to the opposite sides results in a short circuit on C1 and C2. This will result in irreparable damage to SmartBank. Such damage will **NOT** be covered under warranty

If used in conjunction with SmartGauge, failure to provide a proper negative connection to the GND terminal will almost certainly result in irreparable damage to SmartGauge which will **NOT** be covered under warranty.

Remember, we designed this product. We know it inside out, we know what every single component does and know exactly what can cause what symptoms. If the unit is damaged as a result of incorrect installation we **WILL** know and will **NOT** cover it under warranty.

Please, for your own benefit, heed these warnings.

General Description

This manual covers the SmartBank Standard and also the SmartBank Standard Automotive.

SmartBank Standard is a self contained auto-battery combine controller that monitors two battery banks and by making accurate measurements decides when to parallel them to allow simultaneous charging and when to separate them to prevent cross-discharging.

The two units (SmartBank and SmartBank Automotive) are identical in features, functions and physical form. The only differences are the options of the remote panel/switch for each unit and the power saving feature which is not incorporated in the Automotive version.

Unlike conventional split charge systems using diodes or relays SmartBank is not affected by where the charge is coming from, nor does it have to be separately controlled by alternator signals, manual switches etc. There is nothing for you to forget. Neither does it suffer from the voltage drop problems of split charge diodes.

SmartBank automatically controls charging of 2 battery banks no matter which battery bank is being charged. Whether it is an alternator, solar panel, wind generator or AC powered charger SmartBank will take care of it automatically. You make sure your charge source is connected to one battery bank, SmartBank will take care of the other one, totally automatically. No more flat engine start batteries because you forgot to switch the battery selector over. No more uncharged house bank.

Not only is SmartBank better than a standard split charge relay or diode set up, it's actually simpler and quicker to install. No modifications are required to the existing installation. Only *additional* cabling is required thus ensuring warranties are not affected.

Remote Indication and operation

SmartBank interfaces with the SmartGauge battery monitor simply by plugging in an RJ11 type cable. Full details of the features and functions are contained in the SmartGauge owners manual.

Alternatively SmartBank Automotive can be supplied with a dash mounted switch which can be used for emergency battery paralleling to assist engine starting. Integral to this switch is an LED which illuminates to show "connected" status.

Power Consumption

SmartBank has been designed and built using ultra low power semi-conductors and ultra low power design techniques which results in a standby current that is so low, no ON/OFF switch is required. Therefore you can never forget to switch SmartBank on because you never need to switch it off. Standby power consumption is incredibly low at less than 0.1 Ah per week.

Power Save feature

SmartBank also uses switch mode technology to control the relay coil and thus keep the power consumption to an absolute minimum whilst in the connected mode (typically using less than half the power of an equivalent standard split charge relay). This is vital when a small charge source such a solar panel is being relied upon to maintain batteries. Please note that this feature is not available in SmartBank Automotive. It is disabled as standard.

SmartBank consists of the main control box housing the electronics and is installed with a relay of your choice to suit your application, battery and charger size etc. A simple 5 wire connection is required between SmartBank and the relay and GND. SmartBank can be mounted anywhere. Installers will notice the vastly reduced current consumption and much cooler running temperature of their usual relay choice when using this option.

12/24 volt

SmartBank detects whether your installation is a 12 or 24 volt system and adjusts itself automatically.

Remote operation with SmartGauge

Additional features only available with the SmartGauge battery monitor.

LED status indicators showing STANDBY mode and CONNECTED mode. Error reporting warning of problems such as relay failure, insufficient cable sizing, lost communications etc.

Manual override function to manually connect the relay for emergency engine starting.

SmartBank Standard can also be modified (very simply) to operate as a SmartBank Advanced in order to benefit from even more advanced functions. Full details of the modification are available at the website www.smartgauge.co.uk

How SmartBank works

SmartBank continually monitors both battery banks. Should either battery status indicate that a charge source is available (determined from a combination of battery voltage and rate of change of battery voltage over a certain period of time) SmartBank will connect the batteries together via the relay ensuring that both battery banks are charged. This will not happen immediately. There will be a short delay while SmartBank verifies that the charge source is valid. Once the charge source is removed (or a very heavy load is connected that risks flattening all the batteries in the event that the charge source cannot keep up with the current requirements) it will disconnect the banks ensuring that your house bank loads do not discharge the engine battery. All settings are user adjustable.

INSTALLATION

Installation could not be simpler however a few warnings are in order.

WARNING Incorrect wiring of this unit may cause serious damage to the electronic circuit and/or relay that will not be covered by the warranty.

It is recommended that the relay be sited as close to the batteries as possible. Not only does this make the cable installation easier but it also reduces the losses that would otherwise occur when running high battery charge currents through long battery cables.

WARNING The usual precautions regarding relays in proximity to possibly explosive battery gasses should be taken. If in doubt consult a qualified marine/auto electrician.

As all control and indication is by way of the optional remote panel, the siting of the main control unit can be made purely on a "safety and ease of installation basis".

WARNING This unit contains sensitive electronic circuitry and the usual precautions should be taken regarding water, dirt and oil ingress etc.

WARNING Incorrect wiring to any of the terminals may cause serious, irreparable damage to the unit that will not be covered by the warranty. Please take extra care with the C1 and C2 terminals. A short circuit on these will cause very serious damage to SmartBank.

It is recommended that 1mm² cabling be used for the connections to the main terminal block. If any of the connections need to be over 3 metres for any reason then it is recommended that *all*

cables be increased to 1.5mm². This is purely to increase the accuracy of the voltage measurements.

The cabling from the batteries to the main relay terminals cannot be specified in this manual as it depends upon the installation and cable lengths etc. As a rough guide you should use cable that will have a maximum voltage drop of 0.1 volts at the maximum charge rate in your installation. Obviously this depends upon the cable length. If in doubt consult a qualified marine/auto electrician or cable voltage drop chart.

In any event a cable capable of handling the maximum charge capability of the installation **MUST** be used and perhaps also the starter current. Your cable supplier will be able to advise you on all these points. You may of course contact the manufacturers at www.smartgauge.co.uk

Failure to adhere to these instructions could result in overheating of the battery cables.

SmartBank installation diagram

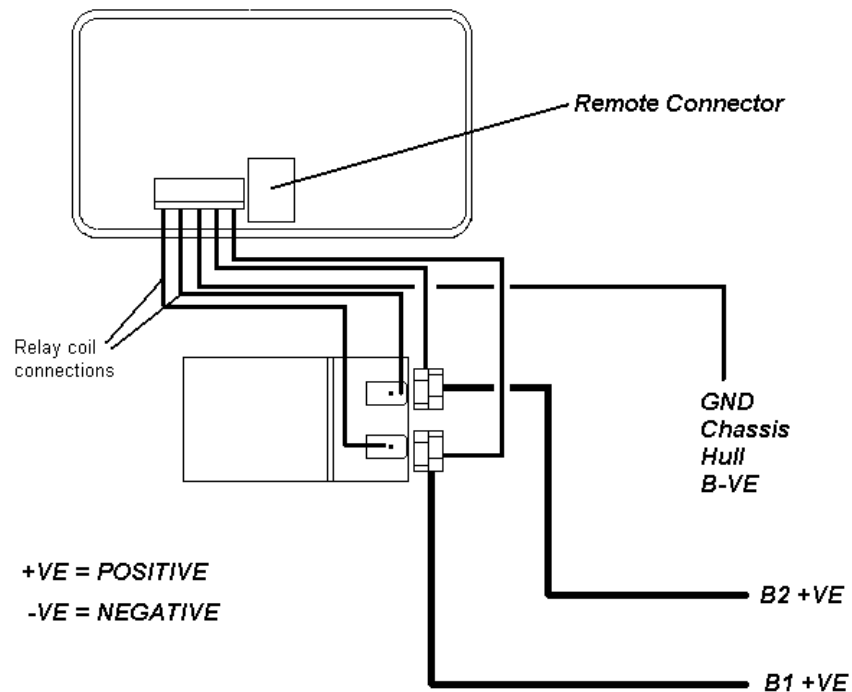

Please note that your relay may look different to the one in the diagram. It will be obvious which contacts are the coil contacts and which are the switched contacts. If you are unsure please contact us or the relay supplier if you supplied your own relay

SmartBank Automotive installation diagram for V2DA remote switch

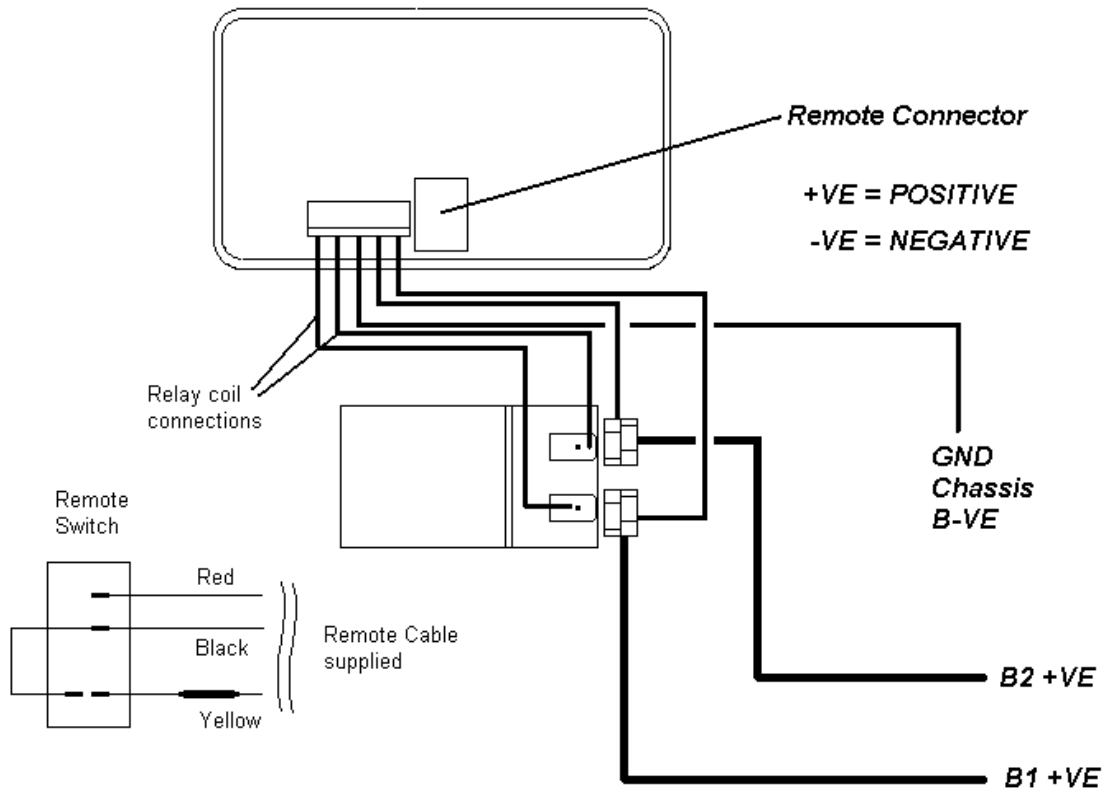

Please note that your relay may look different to the one in the diagram.
It will be obvious which contacts are the coil contacts and which are the switched contacts. If you are unsure please contact us or the relay supplier if you supplied your own relay

SmartBank Automotive installation diagram for VXH2 remote switch

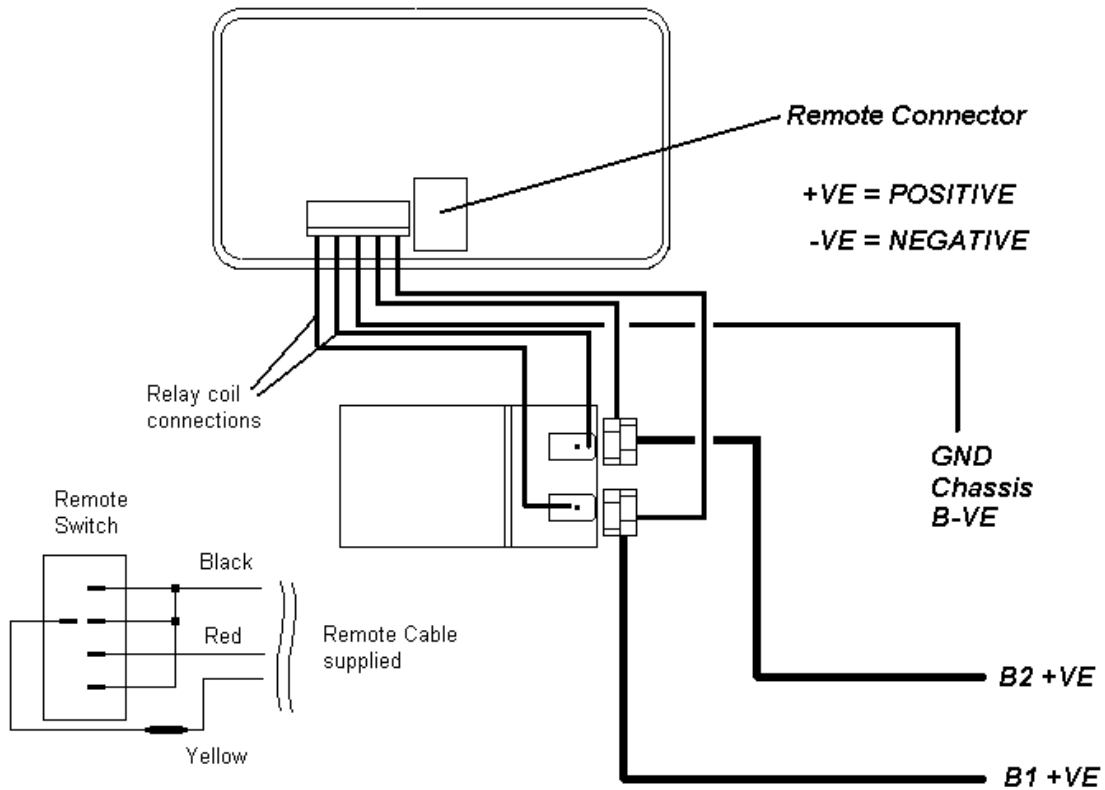

Please note that your relay may look different to the one in the diagram.
It will be obvious which contacts are the coil contacts and which are the switched contacts. If you are unsure please contact us or the relay supplier if you supplied your own relay

SET UP PROCEDURE

Decide on your voltage set points. If you are unsure of these refer to the Battery Types section for standard set up guidelines. Professional installers may have their own preferred settings depending upon the installation. Simply set the adjustments to the required set points as shown in the calibration chart at the end of this manual.

Connect and Disconnect adjustments

There are three adjustments in SmartBank labelled “Connect”, “Disconn” (disconnect) and “Hold”. “Connect” and “Disconn” correspondingly adjust the nominal voltages at which SmartBank will connect and disconnect the battery banks. Basically when the battery voltage (on either battery) *rises* to the connect voltage SmartBank will connect the batteries together. Conversely when the overall battery voltage *falls* to the disconnect voltage SmartBank will disconnect the battery banks. The reality is not quite this simple in that the actual voltages are dynamically altered by SmartBank depending upon how fast the battery voltage rises or falls. In addition to this there are delays before connecting or disconnecting which again are dynamically altered by SmartBank depending upon how fast the battery voltage rises or falls. This drastically improves the performance of SmartBank over a primitive voltage controlled relay. For this reason it may at times appear that SmartBank has disconnected or connected when it should not have done so if the comparison is made to a simple battery voltage measurement. This is not the case. If measurements are made to actually check whether or not true charging is taking place it will be found that SmartBank is indeed connecting and disconnecting at the correct times. A consequence of the dynamically modified voltage set points and delays is that the actual “Connect” and “Disconnect” voltage set points are not actually as critical as it may at first appear.

“Hold” adjustment

The “Hold” function is somewhat more involved. In an installation where the charge source (say an alternator) is connected to the engine battery, and the house (domestic) bank is deeply discharged, it may be the case that upon connection of the two battery banks, the deeply discharged house bank will drop the overall battery voltage below the “disconn” level. This of course will force SmartBank to disconnect the two battery banks. SmartBank will then detect that the voltage on the engine battery has risen (indicating a valid charge source) and reconnect the battery banks. The house bank may then drop the voltage below the “Disconn” level again resulting SmartBank cycling between “Connect” and “Disconn”. This cycling problem could continue for some considerable time until the charge status of the house bank was sufficiently high to enable the alternator to keep the overall voltage above the “Disconn” level.

The “Hold” function introduces a time delay immediately following “Connect” during which SmartBank will not and cannot disconnect the relay no matter what happens to the battery voltage. This time period is adjustable from zero (adjustment fully counter-clockwise) through to 90 seconds (adjustment fully clockwise).

It is recommended that this adjustment be disabled if at all possible in your installation or at least turned to the minimum period required to prevent SmartBank cycling at the initial start of charge.

The “Hold” function is an extra feature added to SmartBank to enable it to operate satisfactorily in poor installations. In a good installation where the batteries, battery chargers etc are correctly sized to each other it will be found that the “Hold” function simply is not required.

If, even after adjustment of the hold function it is found that SmartBank still disconnects then this is because the charge source is simply too small for the overall battery bank size. In this case no amount of adjusting or fiddling will achieve anything. The charger is simply too small. The only course of action is to increase the size of the charge source.

Calibration Chart

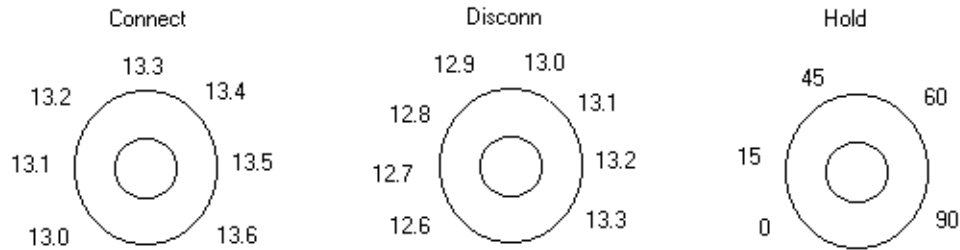

BATTERY TYPES

These are typical figures required for various battery types assuming that the correct battery charger is being used for the batteries. Clearly if the wrong battery charger is being used (i.e. charging at an incorrect voltage for the selected battery type) then these voltages will possibly need to be adjusted. If in doubt consult a qualified marine/auto electrician or contact your dealer.

Wet cell batteries.

Connect voltage 13.2v (26.4 on 24 volt systems)
Disconnect voltage 12.8v (25.6 on 24 volt systems)

Gel cell batteries

Connect voltage 13.4v (26.8 on 24 volt systems)
Disconnect voltage 12.8v (25.6 on 24 volt systems)

AGM batteries

Connect voltage 13.4v (28.8 on 24 volt systems)
Disconnect voltage 12.8v (25.6 on 24 volt systems)

SPECIFICATIONS

Connect voltage range 13.0 to 13.6 volts (26.0 to 27.2 volts on 24 volt systems)
Disconnect voltage 12.6 to 13.3 volts (25.2 to 26.6 volts on 24 volt systems)
Hold time 0 to 90 seconds

Standby current draw < 0.0004 amp (< 0.005 watts) no remote

Connected current draw cannot be specified for SmartBank as it depends almost entirely upon the relay used but will typically be between 25 to 50% of the usual coil current consumption for the relay chosen. SmartBank never uses more than 0.001 amps for it's own purposes while in standby or 0.008 amps maximum in any other mode.

Specifications are subject to change without prior notification.

TROUBLE SHOOTING

Symptom

Green LED lights up solid but the relay does not energise

Possible problem

Faulty connections between C1 or C2 terminals on the connector block and the relay coil.

Faulty relay.

Charge source is switched on, the unit connects then disconnects almost immediately

The charge source is connected to the smaller battery bank and the larger bank is deeply discharged. This can cause the overall voltage to fall below the disconnect voltage when the banks are connected together. Either move the charge source to the larger battery bank or lower the disconnect voltage. Alternatively read the section on the "Hold" function then adjust accordingly.

DISCONNECT voltage and CONNECT voltage are set too close together.

The unit simply will not connect.

Disconnect voltage is set higher than the connect Voltage. Refer to setting up procedure.

Charge source is set lower than CONNECT voltage. Either increase the charge voltage or decrease the CONNECT voltage.

No charge source available or faulty charger.

NOTES FOR PROFESSIONAL INSTALLERS

If you are not a professional installer who is “au-fait” with electronics and battery charging regimes do not read this section. No advice will be given and no correspondence entered into regarding any information contained within this section.

Reduced power consumption

In a power critical application it may be desirable to reduce even the very small power consumption of SmartBank by installing an on/off switch. This can be achieved by fitting a SPST switch in series with R33 on the PCB. This will kill all power to the control circuitry and reduce the current consumption of SmartBank from 400uA to around 10uA. This switch could be replaced with a relay controlled by other equipment.

Defeating the power save feature

At the time SmartBank connects it send a 350mS full power pulse to the relay coil. This ensures that the relay closes fully and quickly. SmartBank then reduces the power delivered to the relay coil by pulsed switch mode techniques. This has several advantages:-

- A) It drastically reduces the “connected” current draw of SmartBank.
- B) It vastly increases the operating life of the relay due to reduced coil dissipation (most relay failures are due to the coil failing not the contacts).
- C) It enables the use of relays which are not continuously rated to be utilised in continuous duty.
- D) It enables a 12 volt relay to be used in a 24 volt installation (provided that 12 volt relay is rated for continuous duty).

In some installations it may be advantageous to defeat the power save feature. One example being an installation in which it is desired that some external equipment can override SmartBank and disconnect or connect the relay in an AND/OR type scenario. Disconnecting the feed from SmartBank to the relay coil will disconnect the relay ok but will not always ensure it can be reconnected due to the relay requiring the full power pulse to close correctly. For this reason the power save feature can be disabled by soldering across the solder contacts on the PCB as shown in the diagram.

Note that the power save feature is disabled by default in SmartBank Automotive.

Battery compartment venting

Wet cell batteries give off explosive gases when being charged. In many installations natural ventilation is sufficient to vent these gases to the outside world but in others it may be necessary to force vent these using a fan. SmartBank is ideal for this additional use by simply using another relay energised by SmartBank to control the fan. Obviously a fan and relay suitable for explosive atmospheres must be used.

Additional relays

SmartBank can safely provide power to relays with a total normal coil current consumption of 3 amps (note that this will not be the actual current draw due to the power save feature), so additional relays can easily be added to parallel, say, a bow thruster or windlass battery. If there is any doubt as to the total coil current consumption then use a small relay energised by SmartBank to control the coil current to the larger relays.

